

NS1003 Installation Guide *Rev 1.1*



CAUTION: High Voltage Wires

WARNING Electricity is dangerous. Before commencing work, ensure that you read and understand these instructions and isolate the relevant circuit. **This product should only be installed by a qualified electrician or heating engineer** and should be installed in accordance to BS 7671 (IEE Wiring Regulations), or to another equivalent standard.

Whats in the box

- 2(or 3) x Assembled Room Thermostat consisting of
 - 1 x Room Thermostat
 - 1 x Wall Mount
- 1 x Assembled Relay Module consisting of
 - 1 x Control Board
 - 1 x Wall Mount
 - 1 X Front Cover
- 1 x Gateway
- 1 x Network Cable
- 1 x Power Supply
- 2(or 3) x Thermostat screw pack
- 1 x Relay Module Screw Pack
- 4(or 6) x Batteries

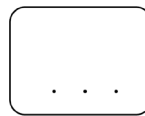

Gateway

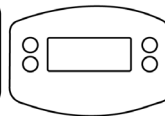

Room Thermostat



Relay Module

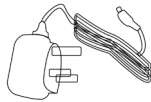

Power Supply

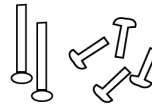

Relay Module
Screw Pack



Thermostat
Screw Pack



Batteries



Network Cable

Introduction

The NS1003 series is designed to control a typical domestic central heating system. The Relay module can switch three independent channels. This would usually be the 2 Central Heating Zones and the Hot Water or 3 Central Heating Zones.

The central heating channel is switched on and off in response to commands from the supplied Wireless Thermostat.

The Hot Water channel is switched on and off at the programmed time intervals that the user sets.

Specifications

Relay Module

Power Supply:	230V~ 50...60Hz, 2.5W (Max)
Switch Type:	2 x SPST, 1 x SPDT
Switch Rating:	3 Amps Total load on all Channels
Radio Frequency:	2.4 GHz
Dimensions:	160 x 100 x 18 mm (35mm including recessed wallmount)

Room Thermostat

Thermostat Power Supply:	2x AA batteries
Controllable Temperature Range:	10 – 30°C
Frost Protection:	Programmable from 0.5 - 30°C
Radio Frequency:	2.4 GHz
Dimensions:	119 x 88 x 22 mm

Gateway

Power input:	5V 1A
Internet Connection:	Wired Ethernet Cable
Radio Frequency:	2.4 GHz
Dimensions:	94 x 79 x 24 mm

Radio Signal

Consideration for location of your new system components and the affects that this may have on the radio signal is extremely important. The signal will travel between units in a straight line and will degrade both with distance and (much more importantly) objects that it has to pass through.

The Relay Module needs to connect to the Wireless Internet Gateway

The Thermostat needs to connect to EITHER the Wireless Internet Gateway OR the Relay Module (It will automatically select the best signal path)

Every house is different and this is NOT a guarantee, but as a guide, the units should be able to communicate with each other through two single skin brick or stud walls.

If the above is not possible, then you may need to consider adding our repeater(s) into the system, or moving one or more of the system components.

Also, the radio can be adversely affected by large metal objects such as your boiler, radiators and mirrors. For best performance, ensure that your units are placed at least 1 metre away from such objects.



Inspire Home Automation
www.inspirehomeautomation.co.uk
contact@inspirehomeautomation.co.uk
01202 798390

Bad Positioning

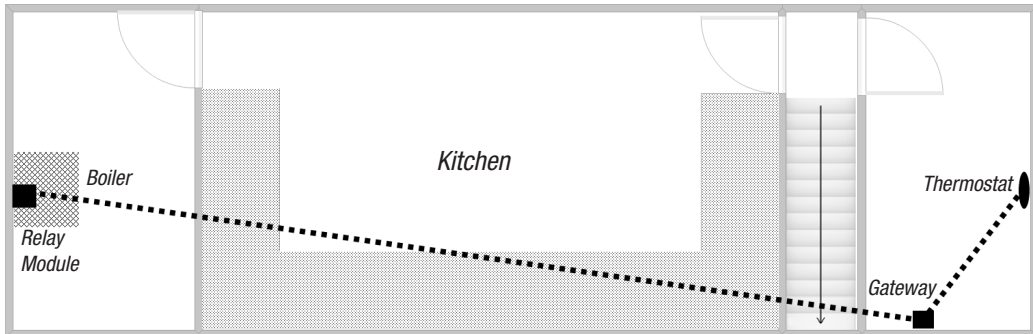

The above image shows the path that the signal will travel to communicate between the 3 units. This is an example of badly positioned items for the following reasons.

- ✗ The Relay Module is positioned under the boiler
- ✗ The signal between the Relay Module and Gateway needs to travel through three walls, a staircase and various kitchen objects, including Units, Oven and Fridge.

Good Positioning

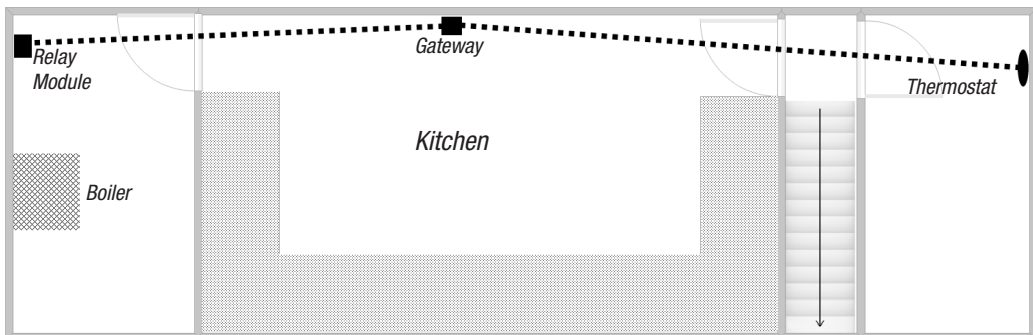

With a few simple changes we have vastly improved the signal.

- ✓ The Relay Module is positioned away from metal objects.
- ✓ The Gateway is positioned centrally between the Thermostat and Relay Module.
- ✓ The Room Thermostat has been positioned to avoid the staircase.

Installation - Gateway

Plug the Gateway into a spare ethernet port on the router using the supplied cable, then plug the supplied power adapter into the back of the gateway and plug into a spare power outlet. Allow 30 seconds for the Gateway to power up. You should see a Green Power Light and a Flashing Amber or Green centre light. The Radio light may be Amber or Green, depending on whether other units are switched on.

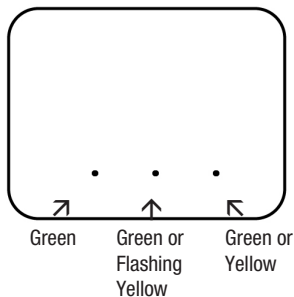

If the Middle light is not on, then the device does not have a valid connection to our Web Servers. Try the following.

- Move our device to a different port. Some routers only have a single 10Mbps port. Try all the ports, especially port 1 and port 4.
- Do you have a valid internet connection? Check by plugging in another device.
- Unplug both the Router and the Gateway. Wait 30 seconds, then plug the router back in. Wait 2 minutes, then plug our Gateway back in.

Installation - Relay Module

Tools Required (Not supplied)

Philips screwdriver

Flat blade screwdriver

Long nosed pliers

BS4662 back box

Isolate the existing supply, then remove the existing Programmer (if fitted). Make a careful note of all wiring locations of the existing programmer before removing any wires. The Relay Module will replace most existing programmers on the market.

Remove the front cover from the Relay Module, this should easily lift off the unit. If the unit has been 'clicked' in place, then grip the recessed part of the rear and pull the chrome part of the front cover off.

Pull out the control panel from the wall mount by placing two fingers on either side whilst holding the wall mount and pulling apart.

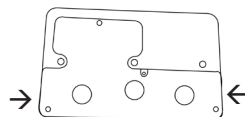

Then secure the wall mount onto the single or double gang back box using the two M3 screws provided.

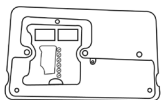

If you are not using an existing back box then you will either need to sink a backbox into the wall, or use an external back box. You can find these in all good hardware stores.

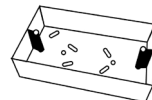

This unit is designed for fixed wiring only. Wire the unit up following the appropriate circuit schematic for your heating system type, ensuring that all wires are securely held and that no bare copper is visible outside the connector block. For ease of wiring, we recommend 1mm² cable, although 1.5mm² can also be used. All wiring should conform to the current IEEE wiring regulations. When replacing an existing programmer, the wiring conversion table, on the back cover, may be of assistance.

All diagrams are in schematic form and earths have been omitted on the drawings for clarity. The NS1003 is a class 2 device and does not require an earth. **Ensure that you do not break earth continuity to the rest of the circuit.** You may need to join the existing earth leads together using a terminal strip. Ensure that the circuit is protected by a 3 amp fuse.

If you are replacing an existing Wired Thermostat with our Wireless Thermostat.

The Wired Thermostat should be removed from the circuit and the Thermostat wiring made safe by disconnecting the wiring and bridging the connections if required. Depending on your existing system, the wired Thermostat may be wired back to either your programmer, the wiring centre / junction box, a zone valve or the boiler itself.

For guidance please refer to the wiring diagrams below, and/or the Wiring Conversions on the last page.

After the wiring has been completed, Push the control board assembly into place and secure using the 4 screws. Before putting on the front cover, we suggest that you test the unit for correct operation.

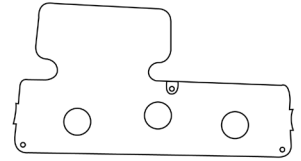

Wiring Diagrams

S Plan Plus

fig. 1

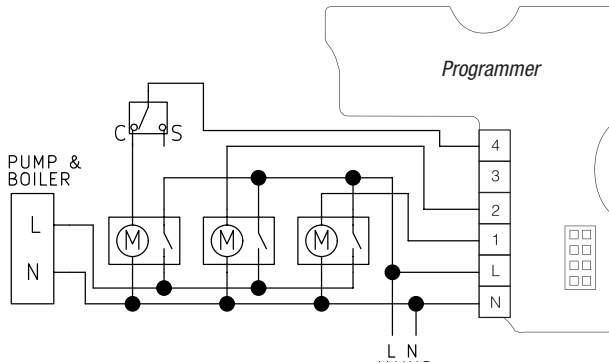

Combi Boiler

Three Zone

fig. 2

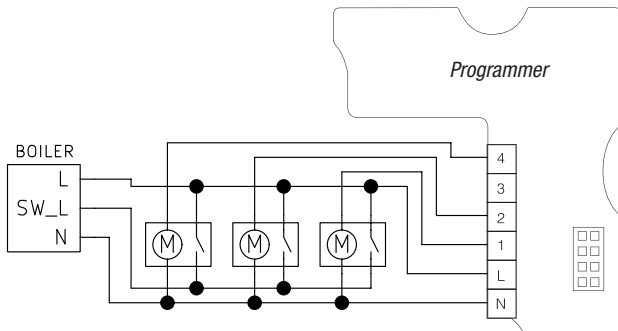

Installation - Thermostat

Remove the two securing screws on the bottom edge of the thermostat and lift the thermostat off the wall mount.

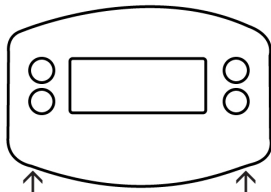

The wall mount is supplied with fixings suitable for a solid wall. If you are fixing to another type of wall, then different fixings may need to be obtained.

Using the wall mount as a template, mark the location of the two holes on the wall. For reference, the two holes are 75.5 mm apart.

Drill suitable holes (6mm diameter for the wall plugs supplied), insert wall plugs and screw the wall mount to the wall.

WARNING be aware of any buried cables before drilling.

Install two AA Alkaline batteries (Supplied) into the back of the room thermostat, and ensure that the display is illuminated.

It is easiest to start the two securing screws off before placing it on the wall, however do ensure that these screws do not protrude inside the room thermostat.

Carefully locate the room thermostat over the wall mount. The room thermostat should slide over the wall mount with little effort. If it does not, do not force it, but check the following then try again

- Securing screws do not protrude into the thermostat
- Wall mount screws are the correct size

Hold the room thermostat in place and lightly tighten the screws underneath to secure the unit – these screws only need the lightest of pressure and must not be over tightened

Testing the system

You should have the following.

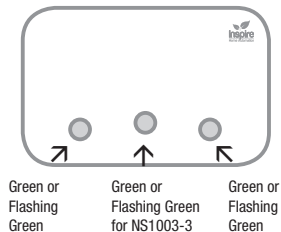
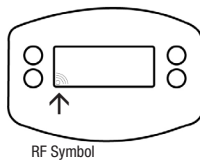
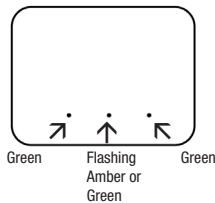

Allow a minute for the Relay Module to connect to the Gateway after they have both been powered up. If after this time, the Relay Module does not have a valid connection, you will see all three lights on the Relay Module rapidly flash Orange every 10 seconds.

If there is no RF link displayed on the Thermostat, and it was switched on before the Gateway, it may take up to 10 minutes to link up. To avoid waiting, ensure the Gateway is plugged in, then reset the Thermostat by pressing and holding all four buttons for 5 seconds. The unit should reset and connect within 30 seconds.

Testing the Hot Water

HW. The light should be out. Press the HW button twice to switch it on.

It will light green and the unit will call for heat on the HW circuit. Check that the boiler has fired up and any zone valves have moved to their appropriate positions. Press the button again to turn the channel off.

Testing the Central Heating

The CH light should be green. On the Thermostat, repeatedly press the 'S' key to cycle between the modes until 'ON' is displayed. Then press and hold the '+' key to raise the target temperature several degrees above the room temperature. eg 25 degrees. The CH light on the Relay module should start to flash Green. Check that the boiler has fired up and any zone valves have moved to their appropriate positions. Press the 'S' key again on the Thermostat to switch it off.

Once you have ascertained that the unit is functioning correctly, push the front cover over the Relay Module until it clips into place. Finally remove the protective film from the cover.

Please leave this installation manual with the user.

Pairing

Your units were all pre paired before they left the factory. If they do not connect up correctly, and you have waited for at least 10 minutes, the most likely reason is radio range, see the section on 'Radio Signal' above.

When all units are connected, you should see:-

Gateway - Green RF light. At least one device is connected to the Internet Gateway.

Thermostat - RF symbol lit in bottom left corner. Connected to Gateway.

Programmer - Green CH light(s). Thermostat connected to Programmer.

In the unlikely event that you need to pair the units to each other then:

To Pair the Programmer to the Internet Gateway.

Press the pairing button on the back of the gateway, (The RF light will flash amber)

Long press the two outside buttons until all three lights start flashing, then short press the two outside buttons

To Pair the Thermostat to the Internet Gateway.

Press the pairing button on the back of the gateway, (The RF light will flash amber)

Press and hold the M & S keys on the Thermostat for 5 seconds, the RF symbol, bottom left should start to flash.

To Pair the Thermostat to the programmer (Only possible after both Thermostat and programmer are connected to the Internet Gateway)

Long press the two outside buttons, this will make all three lights flash. Then press the appropriate button (CH) to pair the central heating channel to a thermostat, this will start the light flashing, press the 'S' and '-' keys on the Room Thermostat until the RF indicator in the lower left hand corner starts to flash.

Wiring Conversions

NS1002	Neutral	Live	HW OFF	HW ON	CH OFF	CH ON	Comments
	N	L	1	2	3	4	
TIMEGUARD TRT038	N	L	P1	P3		P4	Only if Terminals L,P2,P5 are Linked. Assumes HW is on Channel 3
DRAYTON / INVEMSYS MITIME T742R	N	L	1	2		3	Assumes HW is on Channel 3
RELIANCE WATER CONTROLS RW3	N	L	4	6	1	3	Only compatible if nothing wired into existing terminals 2 & 5
DANFOSS FP735Si	N	L	1 ON	2 ON		3 ON	Only compatible if nothing wired into existing terminals 1 OFF, 2 OFF
HORSTMANN CHANNELPLUS H37XL	N	L	1	3	6	5	Only compatible if nothing wired into existing terminals 2 & 4

Table 1

Please note: If there is no cable in the above position, then leave this position blank on the NS1003 controller